

ELP-3500

MULTIMEDIA PROJECTOR

User's Guide

All rights reserved. No part of this publication may be reproduced, stored in a retrieval system, or transmitted in any form or by any means, electronic, mechanical, photocopying, recording, or otherwise, without the prior written permission of SEIKO EPSON CORPORATION. No patent liability is assumed with respect to the use of the information contained herein. Neither is any liability assumed for damages resulting from the use of the information contained herein.

Neither SEIKO EPSON CORPORATION nor its affiliates shall be liable to the purchaser of this product or third parties for damages, losses, costs, or expenses incurred by purchaser or third parties as a result of: accident, misuse, or abuse of this product or unauthorized modifications, repairs, or alterations to this product, or (excluding the U.S.) failure to strictly comply with SEIKO EPSON CORPORATION's operating and maintenance instructions.

SEIKO EPSON CORPORATION shall not be liable against any damages or problems arising from the use of any options or any consumable products other than those designated as Original EPSON Products or EPSON Approved Products by SEIKO EPSON CORPORATION.

EPSON is a registered trademark of SEIKO EPSON CORPORATION.

General Notice: Other product names used herein are for identification purposes only and may be trademarks of their respective owners. EPSON disclaims any and all rights in those marks.

The ENERGY STAR emblem does not represent EPA endorsement of any product or service.

Important Information About Your ELP-3500

Please read the following important information about your ELP-3500 projector.

Important Safety Information

WARNING: Never look into the projector lens when the lamp is turned on; the bright light can damage your eyes. Never let children look into the lens when it is on.

WARNING: Never open any cover on the projector, except the lamp and filter covers. Dangerous electrical voltages inside the projector can severely injure you. Except as specifically explained in this User's Guide, do not attempt to service this product yourself. Refer all servicing to qualified service personnel.

WARNING: The ELP-3500 projector and its accessories come packaged in plastic bags. Keep plastic bags away from small children to avoid any risk of suffocation.

Caution: When you replace the lamp, never touch the new lamp with your bare hands; the invisible residue left by the oil on your hands may shorten the lamp life. Use a cloth or glove to handle the new lamp.

Remote Control Information

You can operate the ELP-3500 by remote control via an infrared (IR) receiver at the front of the projector. The projector may not respond to remote control commands under the following conditions:

- Ambient light is too bright.
- Certain types of fluorescent lighting are used.
- A strong light source shines into the IR receiver.
- Other equipment that emits infrared energy, such as a radiant room heater, is in the room.

These conditions commonly cause problems for most infrared-controlled equipment. Try the following solutions:

- The remote control unit's batteries may be low on power; replace them.
- Dim the ambient lighting and/or turn off any fluorescent lights.
- Close any window coverings and/or move the projector out of direct sunlight.
- Turn off other equipment that emits infrared energy.

If the remote control still does not work properly, remember you can always control your computer-based presentation directly from the computer, even in an environment containing one of the conditions listed above.

FCC Compliance Statement For United States Users

This equipment has been tested and found to comply with the limits for a Class B digital device, pursuant to Part 15 of the FCC Rules. These limits are designed to provide reasonable protection against harmful interference in a residential installation. This equipment generates, uses, and can radiate radio frequency energy and, if not installed and used in accordance with the instructions, may cause harmful interference to radio or television reception. However, there is no guarantee that interference will not occur in a particular installation. If this equipment does cause interference to radio and television reception, which can be determined by turning the equipment off and on, the user is encouraged to try to correct the interference by one or more of the following measures.

- Reorient or relocate the receiving antenna.
- Increase the separation between the equipment and receiver.
- Connect the equipment into an outlet on a circuit different from that to which the receiver is connected.
- Consult the dealer or an experienced radio/TV technician for help.

WARNING

The connection of a non-shielded equipment interface cable to this equipment will invalidate the FCC Certification of this device and may cause interference levels which exceed the limits established by the FCC for this equipment. It is the responsibility of the user to obtain and use a shielded equipment interface cable with this device. If this equipment has more than one interface connector, do not leave cables connected to unused interfaces. Changes or modifications not expressly approved by the manufacturer could void the user's authority to operate the equipment.

For Canadian Users

This Class B digital apparatus meets all requirements of the Canadian Interference-Causing Equipment Regulations.

Cet appareil numérique de la classe B respecte toutes les exigences du Règlement sur le matériel brouilleur du Canada.

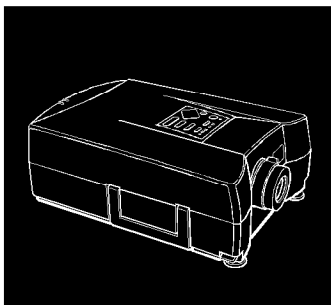

Contents

Introduction	ix
Getting the Most Out of Your Projector	X
Remote control	X
Control panel	xi
Optional accessories	xi
About This Manual	xii
Safety Instructions	xiii
Where to Get Help	xv
Electronic support services	xv
Energy Star Compliance	xvii
1 Installation	1
Unpacking the Projector	2
Additional components	3
Setting Up the Projector	3



Connecting to a Computer	6
Connecting to a PC desktop computer	7
Connecting to a PC laptop computer	8
Connecting to a desktop Macintosh	10
Connecting to a Power Book.	12
Connecting to a Video Source	14
Connecting to an Audio Source	16
Connecting audio from a video source (such as a VCR)	16
Connecting audio from a desktop or notebook computer	17
Connecting to an External Speaker or PA System	17
2 Using the Projector	19
Turning the Equipment On and Off	20
Sleep mode	22
Focusing and Positioning the Screen Image	22
Controlling the Projector	24
Using the remote control	24
Using the control panel	26
Projector Status Indicators	27
Warning lights	27
Status lights	27
3 Using the Menus	29
Using the Main Menus	30
Computer image main menu	30
Video image main menu.	31
Changing Menu Settings	32
Using the control panel	32
Using the remote control	33



Using the SETTINGS Screens	34
Computer image SETTINGS screen	34
Video image SETTINGS screen	35
Using the Option Menus	35
Computer image option menu	36
Video image option menu	37
Using Projector Setups	38
Storing a setup	39
Recalling a setup	40
Clearing a setup	40
4 Maintenance	41
Cleaning the Lens	42
Cleaning the Projector Case	42
Cleaning the Air Filter	43
Replacing the Lamp	44
Resetting the lamp timer	47
5 Troubleshooting	49
Problems with the Projector	50
Problems with the Image or Sound	52
6 Technical Specifications	55
Supported monitor displays	57
Monitor and VGA connector pin assignments	58
Glossary	59
Index	61

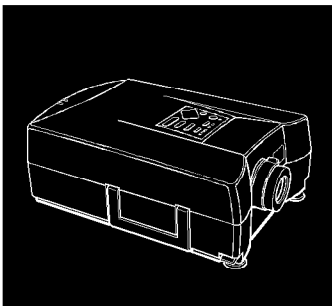

Introduction

The compact, lightweight, SVGA-capable EPSON® ELP-3500 Projector lets you project computer and video images onto a large screen for full-color presentations. You can connect the projector simultaneously to two image sources; one can be your PC or Apple® Macintosh® computer and the other can be a video source, such as a VCR, camcorder, digital camera, or laser disc player. One or both image sources can supply audio.

The projector displays images in full color (16,670,000 colors) at a native resolution of 640 x 480 pixels, and uses a patent-pending technology to resize 800 x 600 images. It produces bright images that you can see easily in rooms light enough to take notes. You can play audio on the projector's internal speaker or route the sound to external speakers for amplification.

You control the projector through a hand-held remote control that lets you switch between image sources and make adjustments to the projected image. The remote control also works as a wireless mouse to control operations on your computer's screen during presentations.

The projector supports any computer capable of SVGA or VGA output, including IBM®-compatible PCs and laptops as well as Apple Macintosh computers, including the PowerBook™ and Power Macintosh.™ The video source can be NTSC, PAL, or SECAM in composite video or S-Video format.

Getting the Most Out of Your Projector

The projector comes with a full set of features that allow you to control the settings for the image display, video, and audio. To get the most out of your projector, read this section for a quick summary of the important features.

Remote control

The buttons on the remote control let you change the volume, mute the A/V, switch from one image source to the other, or use the remote control as a wireless mouse. You can make other adjustments by using the remote control's Menu button to access the projector's menu system. These menus, which you can superimpose on the projector screen, let you control brightness, contrast, color, tint, image position, and other settings.

To use the remote control as a wireless mouse, you simply connect the projector to your computer with the mouse cable. If you purchase the ELP Communication Kit, you can also customize buttons on the remote control to perform functions you select.

Control panel

The control panel buttons on the projector duplicate the remote control buttons and let you perform additional functions. Using the control panel's Preset button, you can save projector settings for instant recall when you need them. Control panel buttons also let you adjust the tracking and sync for computer images.

Optional accessories

To enhance your use of the projector, EPSON provides the following accessories:

- Polarized screens, designed specifically for use with the projector. They let you project images in a bright, illuminated room, making it unnecessary to dim lights to view the projected image. The polarized screen comes in two sizes: 40" and 60" diagonal.
High Bright Screen 40: ELPSC01
High Bright Screen 60: ELPSC02
- Carrying cases especially designed for the projector and its cables. Both a soft and hard case are available.
Soft Carrying Case: ELPKS04
Hard Carrying Case: ELPKS05
- Replacement lamp and air filter.
Lamp with Filter: ELPLP02
- Software package for ELP-3500.
ELP Communication Kit: ELPSW01

-
- A switch box that lets you connect two computers to the projector at the same time, and then switch between images from the two computers during your presentation.

Selector: ELPST01

You can purchase these accessories from your ELP-3500 dealer or by calling EPSON Accessories at (800) 873-7766.

About This Manual

Chapter 1, “Installation,” gives step-by-step instructions on setting up the projector and connecting it to your computer, video source, and other optional equipment. Read the installation procedures that apply to your environment.

Chapter 2, “Using the Projector,” tells how to turn on the projector, focus and position the image, and control simple projector settings using the remote control or the control panel.

Chapter 3, “Using the Menus,” describes how to use the projector menus to adjust image brightness and contrast, video color and tint, and other settings. It also explains how to save and recall projector setups.

Chapter 4, “Maintenance,” describes how to maintain the projector in good working order.

Chapter 5, “Troubleshooting,” tells you how to interpret the projector’s warning lights and gives helpful information for avoiding errors, optimizing image quality, and solving problems.

Chapter 6 provides technical specifications.

Safety Instructions

Follow these safety instructions when setting up and using the projector:

1. Do not place the projector on an unstable cart, stand, or table.
2. Do not use the projector near water or sources of heat.
3. Use attachments only as recommended.
4. Use the type of power source indicated on the projector. If you are not sure of the power available, consult your dealer or power company.
5. Insert the projector's three-wire grounding-type plug into a properly grounded outlet. If you have a two-prong outlet, contact an electrician to replace it. Do not hold the plug with wet hands.
6. Take the following precautions for the plug. Failure to comply with these precautions could result in sparks or fire.
 - Do not insert the plug into an outlet with dust present.
 - Insert the plug firmly into the outlet.
7. Do not overload wall outlets, extension cords, or integral convenience receptacles. This can cause fire or electric shock.
8. Do not place the projector where the cord can be walked on. It may result in fraying or damage to the plug.
9. Unplug the projector from the wall outlet before cleaning. Use a damp cloth for cleaning. Do not use liquid or aerosol cleaners.

-
10. Do not block the slots and openings in the projector case. They provide ventilation and prevent the projector from overheating. Do not put the projector on a sofa, rug, or other soft surface or in a built-in installation, unless proper ventilation is provided.
 11. Never push objects of any kind through cabinet slots. Never spill liquid of any kind into the projector.
 12. Except as specifically explained in this Owner's Manual, do not attempt to service this product yourself. Refer all servicing to qualified service personnel. Opening or removing covers may expose you to dangerous voltages and other hazards.
 13. Unplug the projector during lightning storms or when it will not be used for extended periods.
 14. Do not place the projector and remote control on top of heat-producing equipment or in a heated place, such as a car.
 15. Unplug the projector from the wall outlet and refer servicing to qualified service personnel under the following conditions:
 - When the power cord or plug is damaged or frayed.
 - If liquid has been spilled into the projector, or it has been exposed to rain or water.
 - If it does not operate normally when you follow the operating instructions, or if it exhibits a distinct change in performance, indicating a need for service.
 - If it has been dropped or the cabinet has been damaged.

Where to Get Help

EPSON provides customer support and service through a network of authorized EPSON Customer Care Centers. Dial (800) 922-8911 for the nearest location or the following services:

- Fax-on-Demand access to EPSON's technical information library
- Literature on current and new products
- The location of your nearest Authorized EPSON Reseller or Customer Care Center
- Technical information on installation, configuration, and operation of EPSON products
- Customer relations.

For answers to commonly asked questions about EPSON products 24 hours a day, 7 days a week, call EPSON Sound Advice at (800) 442-2110.

You can purchase manuals, accessories, or parts from EPSON Accessories at (800) 873-7766 (U.S. sales only). In Canada, please call (800) 463-7766 for dealer referral.

If you need help using software with an EPSON product, see the documentation for that program for technical support information.

Electronic support services

You can access helpful tips, specifications, DIP switch or jumper settings, drivers, FAQs, sample files, application notes, and EPSON product bulletins 24 hours a day, 7 days a week, using a modem and one of the online services below.

World Wide Web

From the Internet, you can reach EPSON's Home Page at
<http://www.epson.com>

EPSON Internet FTP Site

If you have Internet FTP capability, use your Web browser (or other software for FTP downloading) to log onto <ftp.epson.com> with the user name anonymous and your E-mail address as the password.

EPSON Download Service

You can call the EPSON Download Service BBS at (800) 442-2007. Set your communications software to 8 data bits, 1 stop bit, no parity. Modem speed can be up to 28.8 Kbps.

EPSON Fax-on-Demand Service

You can access EPSON's technical information library by calling (800) 442-2110 or (800) 922-8911 and selecting the appropriate phone option. You must provide a return fax number to use Fax-on-Demand.

EPSON Forum on CompuServe®

Members of CompuServe can type GO EPSON at the menu prompt to reach CompuServe's Epson America Forum. As an owner of an EPSON product, you are eligible for a free introductory CompuServe membership, which entitles you to an introductory credit and your own user ID and password. To take advantage of this offer in the U.S. or Canada, call (800) 848-8199 and ask for representative #529.

Energy Star Compliance

As an ENERGY STAR Partner, EPSON has determined that this product meets the ENERGY STAR guidelines for energy efficiency.



The EPA ENERGY STAR Office Equipment Program is a voluntary partnership with the computer and office equipment industry to promote the introduction of energy-efficient personal computers, monitors, printers, fax machines, and copiers in an effort to reduce air pollution caused by power generation.

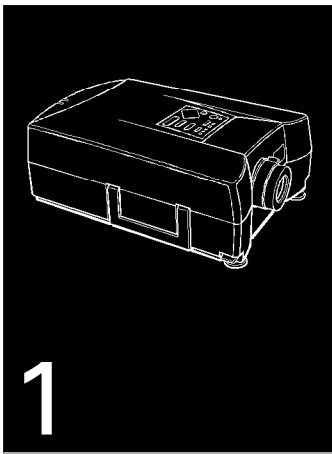

Installation

This chapter describes how to unpack, set up, and connect your projector to other equipment. You must connect the projector to your computer or to a video source such as a VCR, camcorder, digital camera, or laser disc player. Connecting it to other equipment is optional. For example, you may want to connect the projector to both your computer and video source, or set up the projector for one or more of the following:

- Connect the mouse cable to use the remote control as a wireless mouse.
- Provide audio for one or both image sources. The audio source can be the computer, video source, or another device such as a stereo.
- Connect to an external speaker or PA system to amplify the audio.

Unpacking the Projector

When you unpack the projector, make sure you have all these components:

- Projector
- Remote control
- 2 AA batteries
- Power cord
- ELP computer video cable
- Macintosh video adapter
- Lens cover
- Video/audio cable
- Audio cable
- PS/2 mouse cable
- Macintosh mouse cable

Depending on the configuration of your equipment, you may not need all these components.

Save all packaging materials in case you need to ship the projector in the future. Always transport the projector in its original packaging or the equivalent.

- To receive an S-Video signal, you need an S-Video cable. One is usually provided with your video device.

Additional components

Depending on how you plan to use the projector, you may need additional components:

- For a Macintosh PowerBook, you need a video-out cable. One is provided for all new PowerBooks that have video-out capability. If your PowerBook does not include one, see your Macintosh dealer.
- To connect the projector to an external sound system, you need an RCA-to-3.5 mm stereo audio cable. You can obtain one from your computer dealer.
- To connect the mouse cable to your computer, you may require a special connector, cable, or other components. You can obtain these items from your computer dealer. You cannot use the mouse cable with a computer that is not equipped with a PS/2 mouse connector.

Setting Up the Projector

1. Place the projector on a sturdy, level surface within five feet of the computer or video source.



Caution: Do not hold the projector by the lens. This can damage the lens.



Caution: Do not use the ELP-3500 projector upside down. For example, do not mount it on the ceiling.

-
- Place the projector the proper distance from the screen.

The distance between the projector and the screen determines the actual image size. Use the general guidelines in the table below to determine the proper distance.

Image size (diagonal)	Horizontal distance from the projector screen		Vertical distance from the projector to the screen
	Minimum	Maximum	
300 inches	484.3 inches (12.3 m)		20.1 inches (51 cm)
200 inches	322.8 inches (8.2 m)	460.2 inches (11.7 m)	13.4 inches (34 cm)
100 inches	161.4 inches (4.1 m)	228.3 inches (5.8 m)	6.7 inches (17 cm)
80 inches	126 inches (3.2 m)	181.1 inches (4.6 m)	5.5 inches (14 cm)
60 inches	94.5 inches (2.4 m)	137.8 inches (3.5 m)	3.9 inches (10 cm)
40 inches	63 inches (1.6 m)	90.6 inches (2.3 m)	2.8 inches (7 cm)
30 inches	47.2 inches (1.2 m)	66.9 inches (1.7 m)	2.0 inches (5 cm)
21 inches	47.2 inches (1.2 m)		1.2 inches (3 cm)

- Make sure the projector is at a right angle to the screen. Otherwise, the screen image will be distorted.

-
4. Connect one end of the power cord to the projector's power connector. Connect the other end to a grounded electrical outlet. The projector goes into sleep mode, indicated by the orange power status light.



Warning: Never look into the lens when the lamp is on. The projector might come on suddenly, even when it is not operated. This can damage your eyes. It is especially important that children not look into the lens.

5. To insert the batteries in the remote control, slide off the battery compartment cover as shown here.

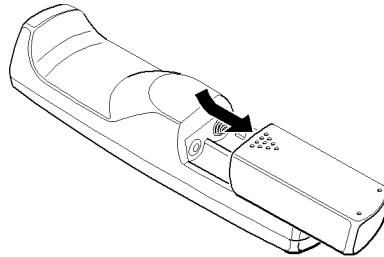

-
6. Insert the two AA batteries included with the projector. Make sure the polarity of the batteries is correct.

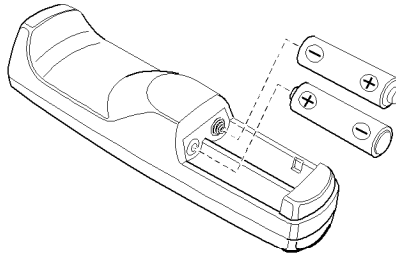

7. Replace the battery compartment cover.

When replacing batteries, take the following precautions:

- Do not mix old and new batteries.
- Replace batteries as soon as they run out. If the batteries leak, wipe away battery fluid with a soft cloth. If fluid gets on your hands, wash immediately.
- Remove batteries if you will not be using the projector for a long period.

Connecting to a Computer

You can connect the projector to any computer capable of standard VGA output, including:

- IBM desktop PC or compatible
- IBM laptop PC or compatible

-
- Apple Macintosh desktop computer, including Macintosh Quadra,® Macintosh Centris,® and Power Macintosh
 - Any Apple PowerBook with video-out capability. This includes all 160, 165, 180, and 500 series PowerBooks.

See the following section that applies to your computer.

Connecting to a PC desktop computer

Before beginning, turn off the projector and computer if they are on.

1. Connect either end of the projector's video cable to the projector's Computer In port.
2. Disconnect the computer's monitor cable from the VGA port on the back of the computer, and connect the projector's video cable to the computer's VGA port.

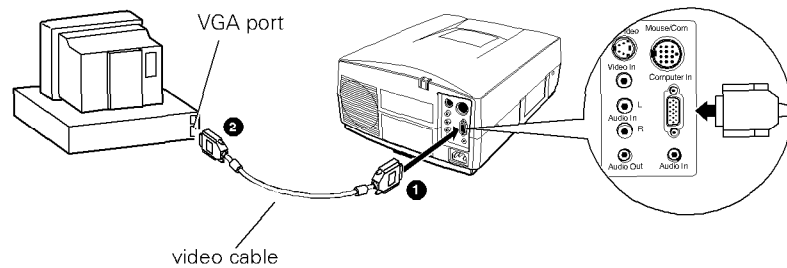

3. Tighten the screws on both connectors to make sure they are fastened securely.

-
4. Connect the bigger end of on the projector's PS/2 mouse cable to the projector's Mouse/Com port.
 5. Disconnect the computer's mouse cable from the mouse port on the back of the computer, and connect the smaller end of the projector's PS/2 mouse cable to the computer's mouse port.

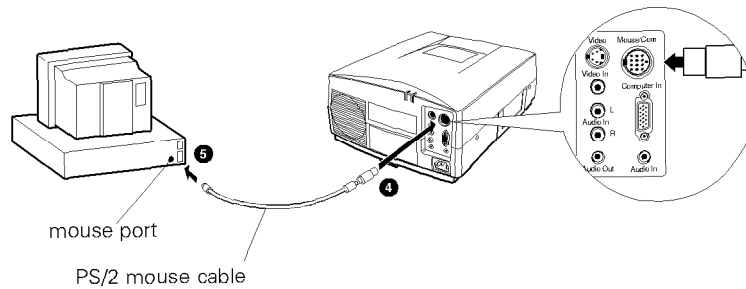

Connecting to a PC laptop computer

Before beginning, turn off the projector and computer if they are on.

1. Connect either end of the projector's video cable to the projector's Computer In port.

-
2. Connect the other end of the projector's video cable to the laptop's monitor port.

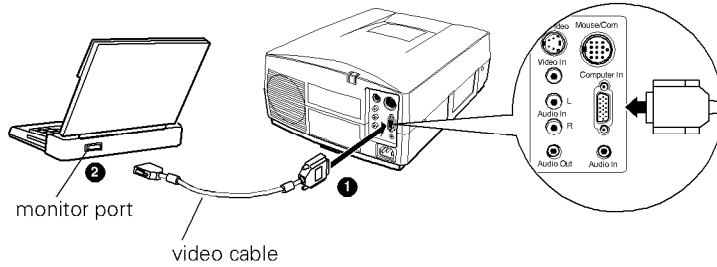

3. Tighten the screws on both connectors to make sure they are fastened securely.
4. Connect the bigger end of the projector's PS/2 mouse cable to the projector's Mouse/Corn port.

5. Disconnect the computer's mouse cable from the mouse port on the back of the computer. Then connect the smaller end of the projector's PS/2 mouse cable to the computer's mouse port.

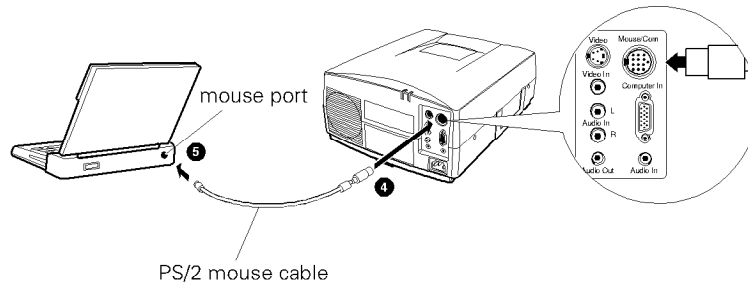

When the external graphics port is activated, some laptop computers automatically turn off their internal display. See your computer manual for information on using the internal display.

Connecting to a desktop Macintosh

Before beginning, turn off the projector and Macintosh if they are on.

1. Connect either end of the projector's video cable to the projector's Computer In port.
2. Connect the Macintosh adapter to the other end of the projector's video cable.

-
3. Disconnect the monitor cable from the video port on the back of the Macintosh, and connect the projector's video cable with the Macintosh adapter to the video port.

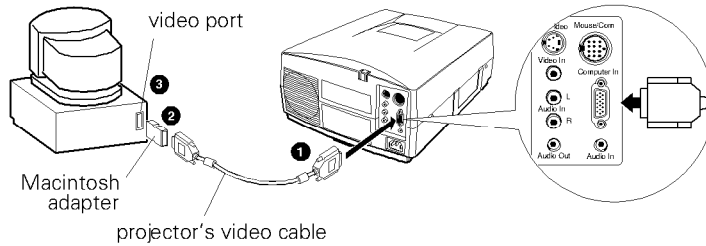

4. Tighten the screws on all the connectors to make sure they are fastened securely.
5. Connect the bigger end of the projector's Macintosh mouse cable to the projector's Mouse/Corn port.

-
6. Disconnect the computer's mouse cable from the mouse port on the back of the computer. Then connect the smaller end of the projector's Macintosh mouse cable to the computer's mouse port.

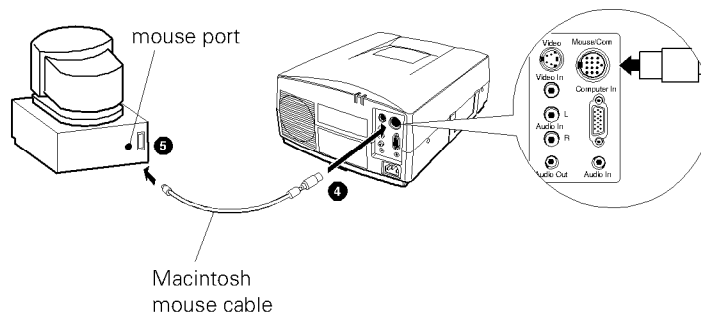

Connecting to a PowerBook

Your PowerBook must have a video-out capability. See page 7 for more information.

Before beginning, turn off the projector and computer if they are on.

1. Connect either end of the projector's video cable to the projector's Computer In port.
2. Connect the video-out cable that comes with your PowerBook to the video-out connector on the back of the PowerBook.
3. Connect the Macintosh adapter to the other end of the projector's video cable.

4. Connect the video-out cable to the other side of the Macintosh adapter on the projector's video cable.

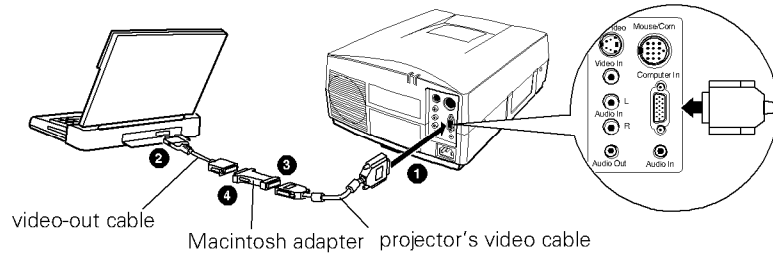

5. Tighten the screws on all the connectors to make sure they are fastened securely.
6. Connect the bigger end of the projector's Macintosh mouse cable to the projector's Mouse/Corn port.
7. Disconnect the computer's mouse cable from the mouse port on the back of the computer, and connect the smaller end of the projector's Macintosh mouse cable to the computer's mouse port.

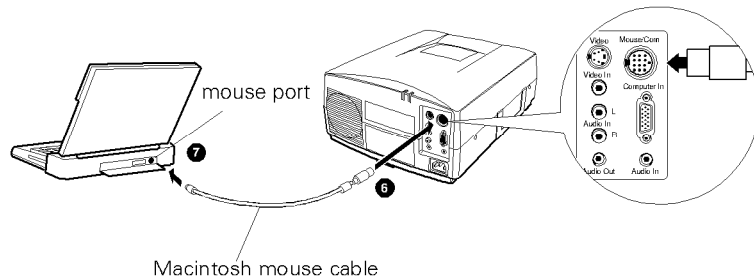

8. In the PowerBook's Display Control Panel, select Mirroring.

Connecting to a Video Source

You can also connect a video tape deck, a camcorder, a laser disc player, or any other compatible video image source to the projector.

The projector can receive composite video or S-Video. You have composite video if your video source has a one-pin RCA video jack. You have S-Video if your video source has a four-pin video jack.

Note: The projector is not compatible with a cable TV-style F connector.

You can connect to both an S-Video and a composite video source at the same time. However, the projector automatically selects the S-Video source. To display composite video, you need to disconnect the S-Video source.

The projector supports NTSC, PAL, and SECAM video formats, and automatically detects and identifies the video format. However, you can specify that a single broadcast format be detected. (See “Using the Option Menus” in Chapter 3.) Note that the projector will then be able to detect only one type of video signal.

The type of cable you use to connect the video source to the projector depends on whether you have composite video or S-Video. For composite video, use the video/audio cable supplied with the projector. For S-Video, use the S-Video cable supplied with your video device or obtain one from your computer dealer.

To connect a video source to the projector:

1. Turn off the projector and video source if they are on.

2. If your video source uses a small, round, one-prong composite (RCA) video connector, you'll need the video/audio cable that comes with the ELP-3500. If your video source uses a large, round, four-prong S-Video connector, you will need to purchase an S-Video cable.
3. For composite video, connect the yellow RCA plug on one end of the video/audio cable to the projector's Video In jack. Connect the other yellow RCA plug to the video-out jack of your video source. (The red and white plugs carry audio. For information about audio, see page 16.)

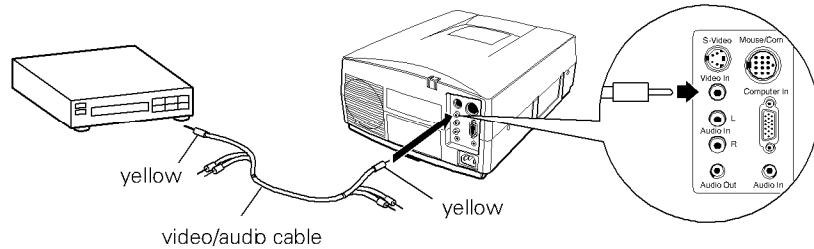

For S-Video, insert one end of the S-Video cable into the projector's S-Video jack. Insert the other end into the S-video-out jack of your video source.

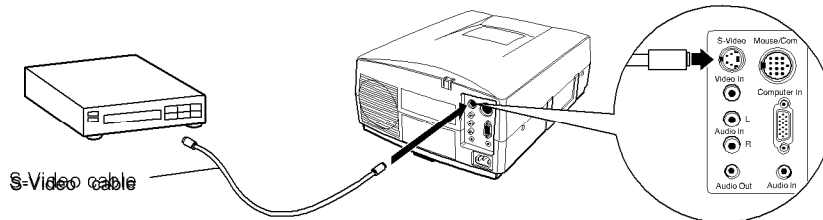

Connecting to an Audio Source

The projector has two kinds of input for audio: one single-jack input for your computer and one two-jack input for your video source. The video source input has an L jack to control the left audio channel and an R jack to control the right audio channel. If you are connecting to a video source that has only a single plug, connect it to either the L or the R Audio In jack.

Connecting audio from a video source (such as a VCR)

Before beginning, turn off the projector and video source if they are on.

1. Connect one end of the video/audio cable to the Audio In jacks of the projector. Insert the white plug into the L Audio In jack and the red plug into the R Audio In jack.
2. Connect the other end of the video/audio cable to the audio output jacks of the video source. Connect the white plug to the left channel and the red plug to the right channel.

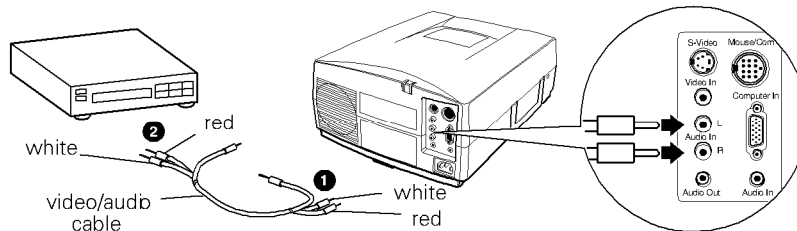

Connecting audio from a desktop or notebook computer

1. Turn off the projector and computer if they are on.
2. Connect either end of a 3.5 mm stereo miniplug audio cable to the Audio In jack on the projector. (You will need to purchase this cable.)

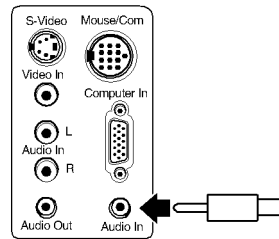

3. Connect the other end of the 3.5 mm stereo miniplug audio cable to the audio output jack on the computer.

Connecting to an External Speaker or PA System

For most small- or medium-sized rooms, the projector's internal speaker is sufficient. If you need extra amplification for a large room, you can connect the projector to an external amplified speaker or PA system.

To connect the projector to an external sound system, you need to obtain an RCA-to-3.5 mm stereo audio cable. You can get one from your computer dealer.

1. Turn off the projector and speaker or PA system if they are on.
2. Connect the cable's 3.5 mm stereo miniplug to the projector's Audio Out jack.
3. Connect the RCA plug to the external amplified speaker or PA system. Insert the cable's red plug into the R jack, and the white plug into the L jack.

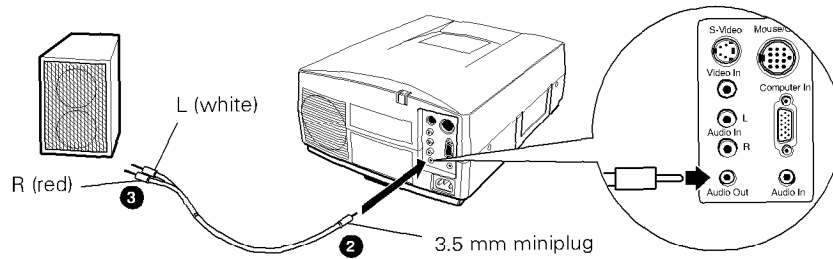

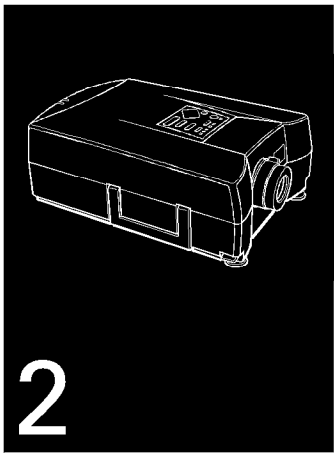

Using the Projector

This chapter provides the following information about using your projector:

- Turning the equipment on and off
- Focusing and positioning the image
- Controlling the projector with the remote control and the control panel
- Monitoring the status of the projector.



Turning the Equipment On and Off

Always turn on the projector and its attached equipment in the following order:

1. Video source (such as a VCR), if your video source is not your computer
2. Audio source (if different from computer or video source)
3. Projector
4. External amplified speaker or PA system (if necessary)
5. Computer.

Remove the projector's lens cap. Then press the Power button on the remote control or the projector's control panel to turn on the projector. The green power indicator comes on. If computer or video equipment is attached, the computer or video signal is projected. Allow about 30 seconds for full illumination.

◆ *Warning: Never look into the lens when the lamp is on. This can damage your eyes. It is especially important that children not look into the lens.*

Reverse the steps above to turn off your equipment.

When you want to stop projecting images, press the Power button again. The fan remains on, and the green power indicator flashes for about 60 seconds as the projector cools off. When the projector has cooled off, the power indicator changes to orange, and the projector goes into sleep mode (described below).

Note: The projector is designed so that it cannot be turned back on while the power indicator is flashing green. Before pressing the Power button again, wait until the lamp has cooled and the power indicator is orange.

The illustration below identifies the parts of your projector.

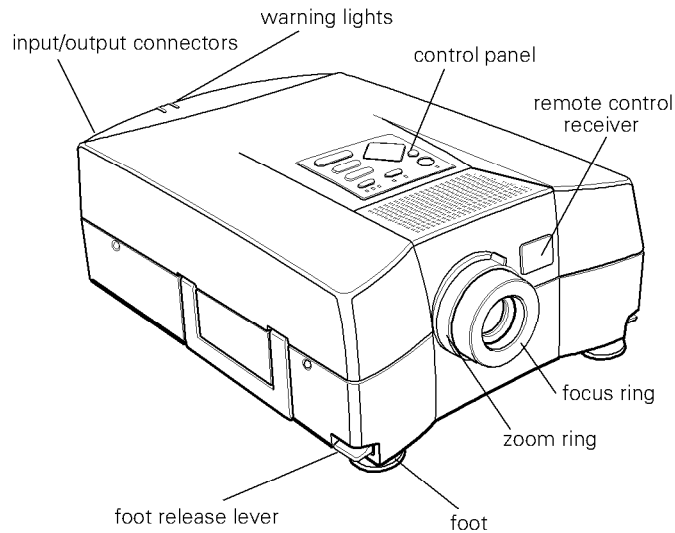

Sleep mode

Sleep mode conserves electricity by automatically turning off the lamp after the projector has not been used for 30 minutes. In sleep mode, the projector's power indicator is orange and only a minimum amount of the projector's circuitry remains on. This conserves electricity, cools the projector, and extends the life of the lamp. When the projector is in sleep mode, you can press the Power button to start projecting images, or you can unplug the projector's power cord.

Focusing and Positioning the Screen Image

When an image appears on screen, check that it is in focus and correctly positioned on the screen. To focus the image, rotate the focus ring, which is the inside ring on the lens. To adjust the size of the image, rotate the zoom ring, which is the outside ring. Rotate the zoom ring clockwise to make the screen image larger or counterclockwise to make it smaller.

If you need to raise or lower the image on the screen, extend or retract the two feet at the bottom of the projector as follows:

1. Stand behind the projector and support the front of it while you press the purple release levers located above the feet. This unlocks the feet so they can move up and down freely. Do not let the projector drop.



Caution: Do not hold the projector by its lens. This can damage the lens.

-
2. While pressing the release levers, raise or lower the projector until the screen image is correctly positioned.
 3. Release the levers to lock the feet in their new position.
 4. To fine-tune the height of the projector, turn the feet clockwise to raise the height or counterclockwise to lower it.

Controlling the Projector

You normally control the projector with the remote control. Buttons on the remote control allow you to do the following:

- Turn power on or off
- Adjust the volume
- Mute the audio and video
- Switch between computer and video images
- Use the remote control as a wireless mouse when the projector is connected to the computer with the mouse cable
- Access the projector menus to adjust the image, audio, video, or display settings (described in Chapter 3)
- Access additional functions available with the optional ELP Communication Kit software.

Functions of the remote control buttons are summarized on page 25. To use the remote control, always point it toward the remote control receiver in the front of the projector. You can use the remote control up to about 33 feet (10 meters) from the front of the projector. (This distance may be shorter if your batteries are low.)

In addition to the remote control, there are buttons on the control panel on top of the projector that let you control it.

Using the remote control

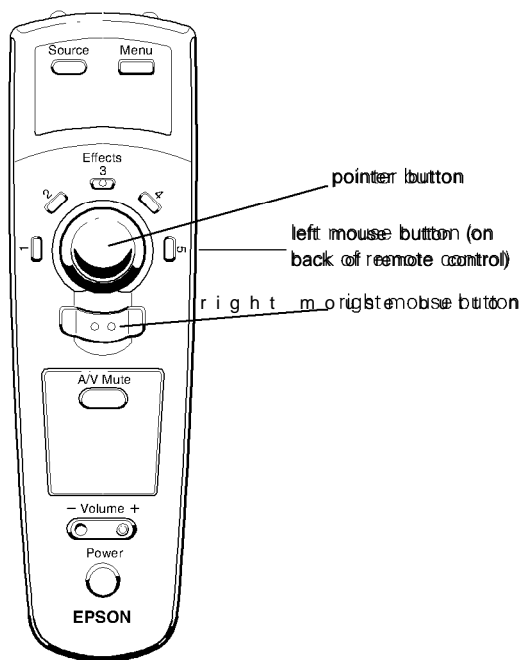

Button	Function
Source	Switches the image source between computer and video equipment.
Menu	Displays or hides the menu.
1 - 5	Perform computer functions that can be assigned using the optional E L P C o m m u
Pointer	Selects a menu item and changes the setting of the selected menu item. Moves the computer pointer (when the projector is connected to the computer with the mouse cable).
Right mouse button	Clicks the right mouse button
AN Mute	Turns off the audio and video.
Volume	Adjusts the volume.
Power	Starts or stops projection.
Left mouse button	Clicks the left mouse button.

Note: The left mouse button is on the back of the remote control.

Using the control panel

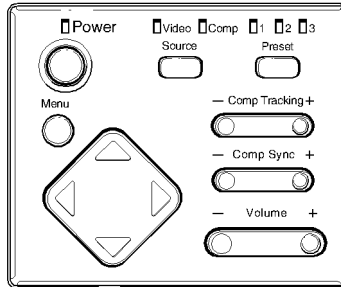

Button	Function
Power	Starts or stops projection.
Menu	Displays or hides the menu
Up, Down Arrow	Selects a menu item
Left, Right Arrow	Changes the setting of the selected menu item
Source	Switches the image source between computer and video equipment.
Preset	Saves projector setups for computer and video images for later recall. (See page 38 for more information.)
Comp Tracking	Matches the projector's internal clock to various computer graphics signals. If vertical lines appear in an image, adjust Comp Tracking to spread the distance between lines until they disappear.
Comp Sync	Synchronizes graphics signals coming from the computer. Adjust this setting if the image is fuzzy or streaked.
Volume	Adjusts the volume

Projector Status Indicators

There are two warning lights on the top rear of the projector, and a row of status lights at the top of the control panel. The control panel lights indicate the projector's operating status.

Warning lights

The two warning lights on the top of the projector alert you when a condition requires your immediate attention. See Chapter 5 for details about what to do when the warning lights come on.

Status lights

The control panel lights let you know the status of the projector at a glance, as described below.

Status light	Function
Power	
Steady orange:	Sleep mode. (The projector is plugged in, but not operational.)
Steady green:	Power is on, the projector lamp is lit, and the projector is projecting.
Flashing green:	The projector is cooling down.
Video, Comp	Indicates whether video equipment (Video) or a computer (Comp) is currently selected as the image source.
1, 2, 3	Indicates the currently selected setup memory area. (See page 38 for more information.)

Note: You cannot turn on the projector when the power light is flashing green to indicate the lamp is cooling down.

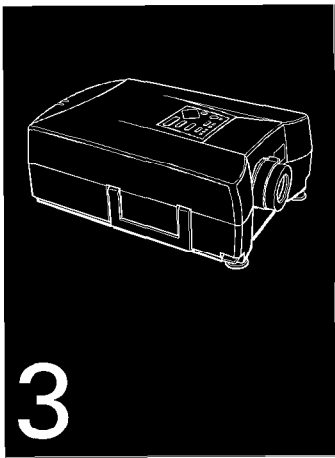

Using the Menus

The projector menus let you do the following:

- Control image brightness and contrast.
- Adjust the horizontal and vertical position and red, green, and blue strength of computer images.
- Change the color and tint of video images.
- View your current projector settings.
- Change the language used in the menus.
- Save and recall projector setups.



Using the Main Menu

You can display the main menu any time by pressing the Menu button on the remote control or the projector's control panel. When you press the Menu button, you see the computer image main menu or the video image main menu, depending on the currently selected image source. The Video and Comp (computer) status lights on the control panel show you which image source the projector is using.

To clear the main menu from the screen, press Menu again. The tables below describe the settings available on each main menu.

*Note: See "Changing Menu Settings" on page 32 **for** details on how to select a menu item and change its setting.*

*Note: **If** the projector is not connected to the currently selected image source or does not support your system's video format or resolution, you cannot display the main menu.*

Computer image main menu

BRIGHTNESS
CONTRAST
H POSITION
U POSITION
SETTINGS	→ ON

Menu Item	Description
BRIGHTNESS	Lightens or darkens the overall image. Increase brightness to lighten an image, or decrease it to darken the image.
CONTRAST	Adjusts the difference between light and dark areas. Increase the contrast to make light areas lighter and dark areas darker. Decrease it to minimize the difference between light and dark areas.
H POSITION	Moves the image left or right. Increase the setting to move the image right, or decrease it to move it left.
V POSITION	Moves the image up or down. Increase the setting to move the image up, or decrease it to move it down.
SETTINGS	When ON, lets you view a screen of current computer image control panel settings.

Video image main menu

Menu Item	Description
BRIGHTNESS	Lightens or darkens the overall image. Increase brightness to lighten an image, or decrease it to darken the image.
CONTRAST	Adjusts the degree of difference between light and dark areas. Increase the contrast to make light areas lighter and dark areas darker. Decrease it to minimize the difference between the lightest and darkest parts of the image.
COLOR	Adjusts color density. Increase the setting for darker and more opaque colors. Decrease it for lighter and less opaque colors.
TINT (NTSC only)	Adjusts the red/green color balance. Increase the tint to add more green to the image, or decrease it to add more red.
SETTINGS	When ON, lets you view a screen of current video image control panel settings.

Changing Menu Settings

To change a menu setting, you use a slider to increase or decrease the value or turn the setting on or off. Follow the steps in the appropriate section below to select a menu item and change its setting.

Using the control panel

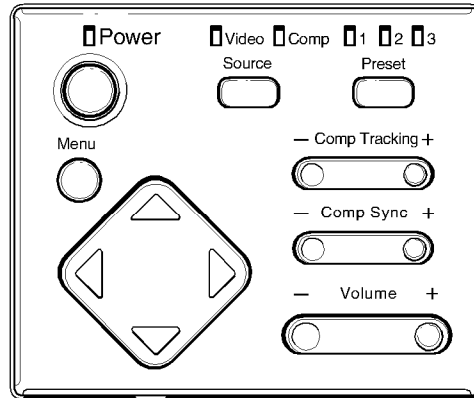

1. Press the Menu button to display the menu.
2. Use the up or down arrow button to highlight the menu item you want to change.
3. When the menu item is highlighted, use the left or right arrow button to change its setting.
4. When you are finished changing settings, press Menu again to clear the menu.

Using the remote control

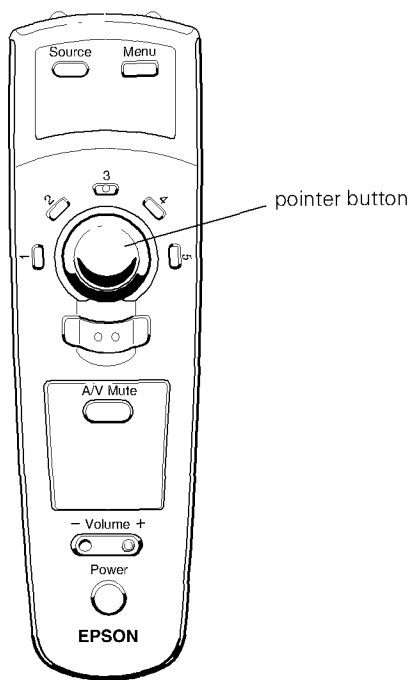

1. Press the Menu button to display the menu.
2. Press the upper part of the pointer button to move the highlighting up one item. Press the lower part of the pointer button to move the highlighting down one item.
3. When the menu item you want to change is highlighted, press the left or right side of the pointer button to change the setting.
4. When you are finished changing settings, press Menu again to clear the menu.

Using the SETTINGS Screens

The SETTINGS screen shows you the control panel settings (see page 26) currently in effect for the selected image source (computer or video). To display a SETTINGS screen, highlight the SETTINGS option on the main menu; then press the right arrow on the control panel or the right side of the remote control pointer button.

A sample SETTINGS screen for each image source is described below.

Computer image SETTINGS screen

SETTINGS	EXIT ↵
	800X600 MODE
TRACKING	+ 100
SYNC	+ 1 0
VOLUME	+ 1 0
PRESET	1
LAMP	1000 H

Current input signal resolution: 800 x 600 (When the projector is in 640 x 480 mode, the SETTINGS screen does not display the mode setting.)

Computer tracking setting: +100 (range of available settings: -120 to +120)

Computer sync setting: +10 (range of available settings: 0 to +30)

Volume setting: **+10** (range of available settings: 0 to +30)

Selected projector setup: **1** (See page 38 for more information.)

Lamp hours used at last start up: 1000 hours (displayed in lo-hour increments)

Video image SETTINGS screen

SETTINGS	EXIT ←
VOLUME PRESET	NTSC + 15 1
LAMP	1000 H

Current input signal type: NTSC

Volume setting: +15 (range of available settings: 0 to +30)

Selected projector setup: 1 (See page 38 for more information.)

To clear a SETTINGS screen and return to the main menu, highlight the EXIT menu option and then press the left arrow on the control panel or the left side of the remote control pointer button.

Using the Option Menus

The option menu contains a number of basic settings you normally do not have to change on a regular basis. To display the option menu for the currently selected image source, hold down the Menu button for at

least three seconds. To clear the option menu from the screen, press Menu again. The tables below describe the option menu settings available for each image source.

Note: See "Changing Menu Settings" on page 32 for details on selecting and changing a menu item setting.

Computer image option menu

RED
GREEN
BLUE
PICTURE	1 → 2
LANGUAGE	E → J

Menu Item	Description
RED	Adjusts red level strength
GREEN	Adjusts green level strength.
BLUE	Adjusts blue level strength.
PICTURE	Specifies image sharpness. 1 enhances color images (by de-emphasizing edges); 2 enhances black and white images (by emphasizing edges).
LANGUAGE	E = English, J = Japanese, D = German, F = French, S = Spanish, I = Italian. Languages scroll in the following order: →E →J →D →F →S →I →

Video image option menu

PICTURE	1	→	2
LANGUAGE	E	→	J
MODE	AUTO		

Menu Item	Description
PICTURE	Specifies image sharpness. 1 emphasizes edges and 2 de-emphasizes edges.
LANGUAGE	E = English, J = Japanese, D = German, F = French, S = Spanish, I = Italian. Languages scroll in the following order: →E →J →D →F →S →I →
MODE	Specifies the video format setting: Auto, NTSC, PAL, or SECAM. See "Connecting to a Video Source" in Chapter 1 for more information.

Using Projector Setups

You can store projector setup parameters for up to six sources (three for computer image sources and three for video image sources) for instant recall when you need them. These setups remain in memory even when you turn off the projector. The settings available for you to save depend on the currently selected image source, as described below.

When the projector is using the computer as its image source, you can change and save these settings:

- Comp sync (control panel setting)
- Comp tracking (control panel setting)
- Brightness (main menu setting)
- Contrast (main menu setting)
- Horizontal position (main menu setting)
- Vertical position (main menu setting).

When the projector is using a video image source, you can change and save these settings:

- Brightness (main menu setting)
- Contrast (main menu setting)
- Color (main menu setting)
- Tint (main menu setting, NTSC only).

Storing a setup



Important! Saving new settings in a memory area automatically replaces any settings previously stored in that memory area.

1. Use the Preset button on the control panel to choose the memory area where you want to store your projector settings. The status light indicates the currently selected memory area (**1**, **2**, or **3**). Pressing the Preset button changes the selected memory area (or turns off the projector setup feature) in this sequence:

→ Off → 1 → 2 → 3

2. While the status light for the memory area you want is lit, check the projected image and make your projector settings. You can adjust the following settings:

- Sync, tracking, brightness, contrast, and vertical and horizontal position for a computer image
- Brightness, contrast, color, and tint (NTSC only) for a video image.

See “Using the control panel” on page 26 in Chapter 2 and “Using the Main Menus” on page 30 for instructions on changing projector settings.

3. After you select your projector settings, hold down the Preset button for about three seconds, until the memory area status light starts flashing. Then release the Preset button; the status light stops flashing and stays on, and the projector setup is stored in the selected memory area.

Recalling a setup

- ◆ *Important! Recalling a setup replaces your current projector settings with the settings that were saved in memory.*

Use the Preset button on the control panel to select the memory area that contains the settings you want to recall.

Clearing a setup

When you don't want a preset projector setup anymore, you can clear its memory area. This removes your settings from the memory area and replaces them with the projector's default settings. To clear a preset setup, follow these steps:

1. Use the Preset button on the control panel to choose the memory area you want to clear.
2. Hold down the Preset button for approximately 15 seconds. The status light alternates between flashing and staying lit; when it remains lit, release the Preset button.

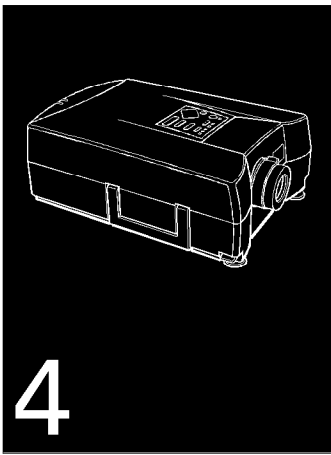

Maintenance

The projector needs little maintenance. You should keep the lens clean, because any dirt or smears appear on the screen. You also need to periodically clean the air filter at the bottom of the projector. Cleaning the air filter is important, because a clogged air filter can block ventilation needed to cool the projector and keep it from overheating. Before you clean any part of the projector, always turn off the projector and unplug the power cord.

The only parts you should replace are the lamp and air filter. If any other part needs replacing, contact your ELP-3500 dealer or a qualified service person.

-
- ◆ *Warning: Never open any cover on the projector, except the lamp and filter covers. Dangerous electrical voltages in the projector can injure you severely. Do not try to service this product yourself except as specifically explained in this Owner's Manual. Refer all servicing to qualified service personnel.*

Cleaning the Lens

Clean the lens whenever you notice dirt or dust on the surface. Lightly wipe the lens surface with a soft, dry, lint-free cloth. To remove dirt or smears on the lens, moisten a soft cloth with an alcohol-based cleaner and gently wipe the lens surface.

Cleaning the Projector Case

To clean the projector case, first unplug the power cord. To remove dirt or dust, wipe the case with a soft, dry, lint-free cloth. To remove stubborn dirt or stains, moisten a soft cloth with water and a neutral detergent. Then wipe the case. Do not use alcohol, benzene, thinner, or other chemical detergents. These can cause the case to warp.

Cleaning the Air Filter

Clean the air filter at the bottom of the projector after every **100** hours of use. If it is not cleaned periodically, it can become clogged with dust, preventing the projector from being ventilated properly. This can cause overheating and damage the projector. To clean the air filter, follow these steps:

1. Turn off the projector and unplug the power cable from the wall outlet.
2. Turn the projector so that its handle is on top so you can access the filter easily.



Caution: Stand the projector with the handle at the top to keep dust from getting inside it.

3. Use a flat-head screwdriver to lift and remove the filter cover.

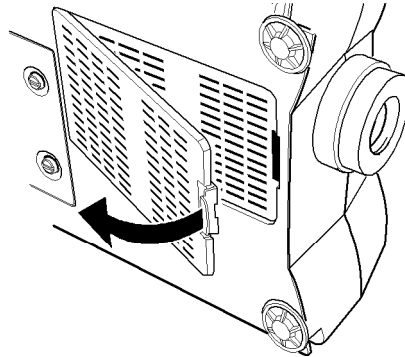

-
4. The filter is attached to the other side of the filter cover. It is recommended that you use a small vacuum cleaner designed for computers and other office equipment to clean the filter. If you don't have one, use a dry, lint-free cloth.

If the dirt is difficult to remove or if the filter is torn, replace it. Contact your ELP dealer or call EPSON Accessories (800-873-7766 in the United States) to obtain a new one. Be sure to request part number 1023658.

5. Replace the filter.
6. Reconnect the power cord to the wall outlet.

Replacing the Lamp

The projector lamp typically lasts for about 4000 hours of use. It is time to replace the lamp when:

- You notice that projected images get darker or start to deteriorate.
- The lamp warning light is red.

Contact your local EPSON dealer or call EPSON Accessories (800-873-7766 in the United States) for a replacement lamp. Use only replacement lamp part number ELPLP02.

◆ *Warning: Let the lamp cool before replacing it. During use, it becomes hot enough to burn you.*

1. Turn off the projector and disconnect the power cord from the wall outlet.
2. Turn the projector over so you can access the lamp cover.

-
3. Use a screwdriver, coin, or similar object to loosen the two retaining screws on the lamp cover. You cannot remove these screws.

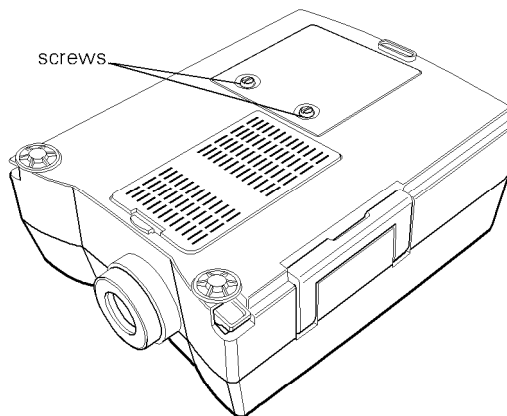

4. When the screws are loose, lift off the lamp cover.

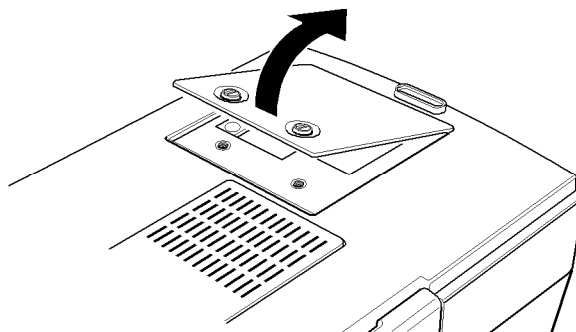

-
5. Use a screwdriver, coin, or similar object to loosen the two screws holding the lamp in position. You cannot remove these screws.

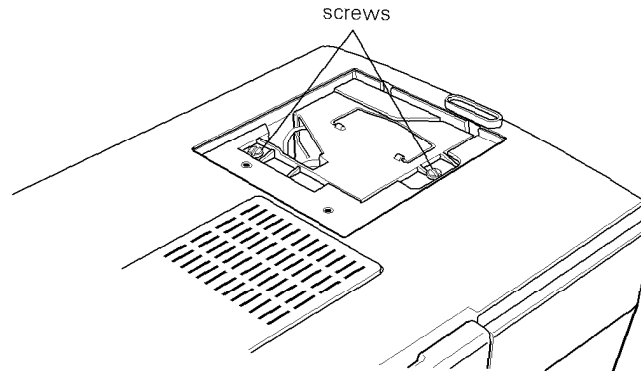

6. Lift up the handle and pull out the lamp.

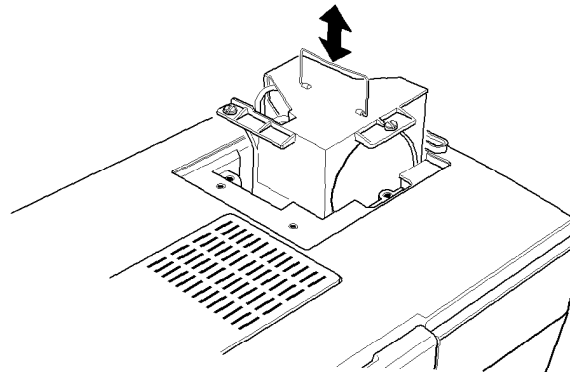

-
7. Gently insert the new lamp by lowering it into position. Make sure it is inserted securely.
 8. Tighten the screws you loosened in step 5.
 9. Replace the lamp cover and tighten the cover screws.

Make sure the lamp cover is securely fastened. The projector turns itself off if the lamp cover is open.

Resetting the lamp timer

After changing the lamp, you need to reset the lamp timer as follows:

1. Make sure the projector is turned off.
2. While holding down the projector's Comp Sync + and Comp Tracking + buttons, Press and hold down the Power button.
3. After status lights 1, 2, and 3 flash ON and OFF at least 3 times, release the Comp Sync +, Comp Tracking +, and Power buttons. The flashing status lights indicate that the lamp timer is reset.

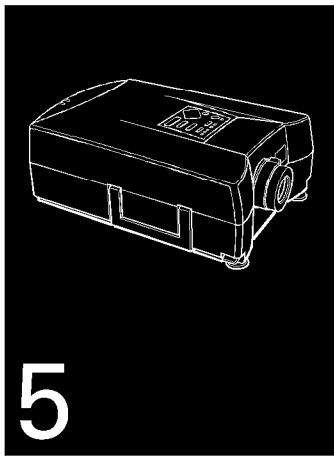

Troubleshooting

This chapter describes the problems indicated by the warning lights and provides information on how to solve problems with the projector. It is divided into the following sections:

- Problems with the projector. See this section if the projector is not working and to find out what the warning lights are indicating.
- Problems with the screen image. See this section if you cannot project an image or if the screen image is not good.

If you have a problem, check the appropriate section and follow all suggestions that apply to your problem. If none of the suggestions solves the problem, call your ELP-3500 dealer or call EPSON. In the U.S. or Canada, call (800) 922-8911.

Problems with the Projector

If you have problems with the projector, first turn it off and unplug the power cord from the wall outlet. Then plug the power cord back in and turn on the projector. If this does not solve the problem, check the warning lights at the top of the projector. These lights alert you to problems with projector operation.

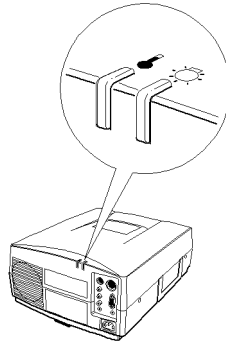

Warning light	Color	Status
Temp	Red	The projector is hot.
Lamp	Red	The lamp needs to be replaced. (See "Replacing the Lamp" in Chapter 4 for instructions.)
Temp and lamp	Flashing red	There may be an abnormality in the projector.

See the following pages for information on what to do when you see these warning lights or encounter other specific problems with the projector.

-
- ▶ **The power status light is flashing green and you cannot turn on the projector.**

The lamp is cooling down. Wait until the light changes to orange and then turn on the projector.

- ▶ **The power status light does not come on.**

Turn off the projector, check that the power cable is connected securely both at the power outlet and the projector, and press the Power button again.

- ▶ **Projected images get darker or start to deteriorate, or the lamp warning light is red.**

Replace the projector lamp as described on page 44.

- ▶ **The temperature warning light is red.**

The projector is overheating, which turns the lamp off automatically. Let the projector cool for a few minutes; then turn it back on. Make sure nothing is blocking the ventilation vents.

The air filter may be clogged. Clean it as described in Chapter 4, and then let the projector cool for a while.

If the projector continues to overheat after you clean the air filter, the problem may be caused by damage to the cooling fan or internal circuits. Contact a qualified service person.

-
- ▶ **The lamp and temperature warning lights are flashing at the same time.**

An abnormality may have occurred in the projector. Turn off the projector and unplug the power cord from the wall outlet. Then plug the power cord back in and turn on the projector. If nothing changes, call the service center.

◆ *Warning: Except as specifically explained in this Owner's Manual, do not attempt to service this product yourself*

Problems with the Image or Sound

- ▶ **An image does not appear on the screen.**

Check that the power light is on and the lens cover is off. Also make sure the cables are installed correctly, as described in Chapter 1.

The correct image source may not be selected. Press the Source button on the remote control or the control panel to choose the other image source.

- ▶ **Only part of the computer image is displayed.**

If the computer's output resolution setting is set higher than 640 x 480, the projector resizes the image. If the computer output is not compatible with this resizing, choose a different display setting on the computer. In Windows 3.1, use Windows Setup in the Main program group. For a Macintosh, choose Control Panels under the Apple menu

and then Monitors; in the Monitors screen, choose Options and make sure Macintosh Hi-Res Display or another 640 × 480 display is selected. For supported display settings, see Chapter 6.

If a 640 × 480 display is selected, see Chapter 6 for supported display settings. You also may need to modify existing presentation files if you created them for a different resolution. See your software manual for specific information.

▶ **The message NO SIGNAL is displayed.**

An image source not connected to the projector is selected, the signal is not being output from the computer, or the signal is not reaching the projector. Make sure the connectors are securely attached to both the projector and the image source. Then check that the image source is selected correctly. When NO SIGNAL is displayed, you cannot access the projector menus.

▶ **A black screen is displayed.**

The computer signal cannot be interpreted by the projector. Verify the display format (see page 57). When you see a black screen, you cannot access the projector menus.

▶ **The image or parts of the image are blurred or not in focus.**

Turn the focus ring on the projector to see if this improves the image. Also check that the projector is within the recommended distance for the size of the screen. (See the table on page 4 for more information.) For the sharpest images, the projector must be perpendicular to the screen and the projection surface must be flat.

Adjust the Brightness and Contrast settings on the Computer Image or Video Image main menu. If you're viewing a computer image, also try adjusting the Comp Tracking and Comp Sync buttons on the projector's control panel.

There may be dirt or smears on the lens. Clean the lens as described in Chapter 4.

▶ **The colors of the image are not right.**

The color balance may be incorrect. If you're displaying a computer image, adjust the red, green, and blue settings in the Computer image option menu. If you're displaying video, adjust the color and tint (NTSC only) settings on the Video image main menu.

▶ There **is no sound.**

First check that the volume setting is not turned all the way down and that the video/audio cable is securely attached to both the projector and the audio source.

The wrong source is selected. Use the Source button on the remote control or control panel to change the source.

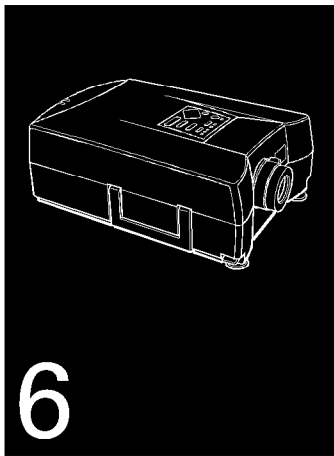

Technical Specifications

General	Type of display	Liquid crystal panel, Thin Film Transistor (TFT)
	Size of liquid crystal panels	1.32 inches (33.6 mm)
	Resolution	640 (horizontal) x 480 (vertical) pixels
	Image size	21 to 300 inches (0.5 to 7 meters)
	Projection distance	4 to 40 feet (1.2 to 12.3 meters)
	Remote control range	33 feet (10 meters)
	Internal speaker system	3 W monaural
	Optical aspect ratio	4 x 3 (horizontal x vertical)
	Zoom ratio	1:1.4

Projector lamp	Type	Metal Halide, DC
	Power	100 W , 85 V
	Part number	ELPLP02
Mechanical	Height	5.9 inches (13.7 cm)
	Width	11.2 inches (28.3 cm)
	Depth	15.1 inches (38.2 cm)
	Weight	14.8 lb (6.7 kg)
Electrical	Voltage	100 to 120 VAC and 200 to 240 VAC
	Rated frequency	50/60 Hz
	Power	150 W, 6 W in Sleep mode ENERGY STAR Compliance
	Consumption	100 to 120 VAC, 1.5 A, 50/60 Hz 200 to 240 VAC, 0.8 A, 50/60 Hz
Environmental	Temperature	Operation: 32 to 104° F (0 to 40° C) Storage: -4 to 140° F (-10 to 60° C)
	Humidity	Operation: 20 to 80% RH, non-condensing Storage: 10 to 90% RH, non-condensing

Supported monitor displays

The projector displays images at a resolution of 640 x 480 pixels. To display a higher resolution image, the projector compresses it to 640 x 480. The following table lists the display formats supported by the projector:

Computer type	Formats	Resolutions
IBM PC and IBM PC compatible	VGA, VESA, JEGA	640 x 480
	CGA	640 x 200
		800 x 600*
Apple Macintosh	Standard 8- and 24-bit color monitor	640 x 480
		832 x 624*
NEC	PC	640 x 480

* The projector uses a patent-pending technology to resize the image to 640 x 480.

Note: The frequencies of some computers may not allow the image to be displayed correctly.

Note: This projector is compatible with DDC-capable graphic sub-systems and boards only.

Monitor and VGA connector pin assignments

The Monitor connector is a female video RGB, 15-pin micro-D-style connector, and the VGA connector is a male video RGB, 15-pin micro-D-style connector. The pin assignments for both connectors are:

Input pin	Signal
1	Red analog input
2	Green analog input with composite sync
3	Blue analog input
4	GND
5	GND
6	Red GND
7	Green GND
8	Blue GND
9	+5 V
10	Sync GND
11	GND
12	SDA
13	Horizontal sync/composite sync input
14	Vertical sync input
15	SCL+

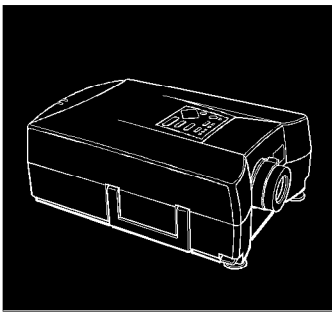

Glossary

Brightness. The balance of light and dark shades in an image.

Composite video. A type of video signal that encodes picture, luminance, and synchronization information so it can be carried in one signal.

Contrast. A measure of the tonal differences between the highlights and shadows of an image. In a high-contrast image, light areas are very bright and dark areas are very dark, with relatively few levels of gray between white and black. Contrast is decreased by adding grays.

NTSC. A 525-line video broadcast format developed by the National Television Standards Committee. NTSC is widely used in North America, Mexico, and Japan.

PAL (Phase Alternation by Line). A 625-line video broadcast format used in Western Europe, India, China, Australia, New Zealand, and parts of Africa.

Resolution. A measure of the amount of detail contained in an image. Resolution can be measured in dots per inch or in pixels. Image sharpness and clarity improve as resolution increases.

RGB. A type of color scheme that defines color as percentages of red, green, and blue.

S-Video. A type of video signal used in S-VHS videotape formats. It transmits luminance and color separately.

SECAM (System Electronique pour Couleur Avec Memoire). A 625-line TV system used in France, Eastern Europe, Russia, and parts of Africa.

Sleep mode. A power-saving feature in which the projector's lamp is turned off when the projector has not been used for 30 minutes. In sleep mode, only a minimum amount of the projector's circuitry remains on.

VGA. Video Graphics Array. A high-resolution display adapter that provides a variety of video modes.

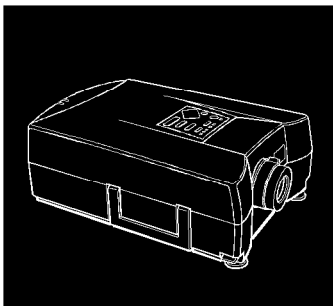

Index

Numerics

- 1, 2, 3** light, 27, 39
- 640 x 480 resolution, ix, 34, 52 to 53, 57
- 800 x 600 resolution, ix, 34, 57

A

- Abnormality, 52
- Accessories, xi to xii, 44
- Adapter, Macintosh, 10 to 12
- Air filter, 41, 43
- Alcohol, 42
- Amplification, 17
- Angle, 4
- Arrow buttons, 26, 32
- Audio source, connecting to, 16 to 17
- Audio In, 16 to 17
- Audio Out, 18

B

- Balance, 31, 54
- Batteries, 5 to 6
- Blank screen, 53
- Blue, 36, 54
- Brightness, 31, 38, 53
- Bulb, 44
- Burn, 44
- Burned out, 51
- Buttons
 - control panel, 26
 - menu, 35
 - remote control, 25
 - video, 52

C

Cable, 3, 15, 17, 52
Cable, mouse, see Mouse cable
Camcorder, 14
Case, 42
Cleaning, 40 to 44, 54
Cloth, 42, 44
Color, 31, 54
Comp
 status light, 27, 30
 sync, 34, 38
 tracking, 34, 38
Comp Sync button, 26
Comp Tracking button, 26
Composite video, 14
CompuServe, xvi
Computer
 connecting to, 6 to 13
 main menu, 30
 option menu, 36
 SETTINGS screen, 34
 signal, 53
Connecting, 1, 6, 16
Connector, 15, 58
Consumption, power, 56
Contrast, 31, 38, 53
Control panel
 buttons, xi, 26, 39
 displaying menus from, 30 to 32

Converter, 3
Cooling, 21 to 22, 27, 41, 44, 51
Cover
 filter, 43
 lamp, 45, 47
 lens, 20, 52
 opening, 42
Crooked screen image, 4

D

Darken, 31
Dealer, 41, 44
Depth, 56
Desktop
 Macintosh, 10
 PC, 7
Dimensions, 56
Dirt, 42, 54
Discharge, 56
Display format, 53, 57
Display setting, 52
Distance, 4, 53, 55

E

Edges, 36
Electrical
 specifications, 56
 voltage, 42
Enlarging screen image, 22

Environmental specifications, 56

EPSON

accessories, xi to xii

Customer Care Centers, xv

Electronic support services, xv to xvi

F

F connector, 14

Fan, 21, 51

Feet, 23

Filter, 41, 43 to 44

Flashing light, 21, 39, 47, 50

Focus ring, 21, 22, 53

Focusing, 22

Format, video, 14

Frequency, 56

Functions, computer, 25

Fuzzy, 26

G

Glossary, 59

Green, 36, 54

H

H position, 31, 38

Handle, 43, 46

Height, 22 to 23, 56

Help, xv to xvi

Hot, 44, 50 to 51

Humidity, 56

I

Image problem, 52

Image source, 52 to 53

Input signal, 35

Internet, xvi

J

Jack, 14 to 18

L

L jack, 16, 18

Lamp

cover, 45, 47

life, 34

replacing, 44 to 47

specifications, 56

timer, 47

warning lights, 50 to 52

Language, 36 to 37

Laptop, 8

Laser disc player, 14

Lens

cleaning, 42, 54

cover, 20, 52

holding projector by, 3

looking into, 5, 20



Light

- lamp, 50
- power, 20 to 22
- temp, 50 to 52

Lighten image, 31

Lights

- status, 27
- warning, 21, 49 to 50

M

Macintosh

- adapter, 10, 12
- connecting to the projector, 10 to 12
- display problems, 52 to 53
- supported monitors, 57

Main menu, 30, 38

Maintenance, 40 to 41

Mechanical specifications, 56

Memory, 38 to 40

Memory area, 27

Menu button, 24 to 25, 32 to 33, 35 to 36

Menus

- choosing language, 36
- main, 30 to 31
- option, 35 to 37

Miniplug, **18**

Monitor displays, supported, 57 to 58

Mouse cable, **1** to 3, 23

Moving the image, 31

Mute, 24 to 25

N

National Television Standards Committee, see NTSC

NTSC, x, 14, 31, 35, 38

O

Opaque, 31

Option menu, 35

Outlet, 5

Overheating, 41, 43, 51

P

PA system, 1, 17

Packaging, 2

Phase Alternation by Line, see PAL

PAL, 14

PC, 57

PC desktop, 7 to 8

PC laptop, 8 to 9

Picture **1** or **2**, 36 to 37

Pin assignments, 58

Plugs

- red, 16, **18**

- white, 16, **18**

- yellow, 15, **18**

Pointer button, 24 to 25, 33

Polarized screen, xi

Power

- button, 23 to 26
- cable, 43, 51
- cord, 4
- lamp, 56
- light, green, 20 to 21, 27, 51
- light, orange, 5, 22, 27, 51
- outlet, 52
- turning on and off, 20 to 22

Power indicator, see Power light, green *and*
Power light, orange

PowerBook, **12** to 13

Presentation, 53

Preset

- button, 26, 39
- setup parameters, 38 to 40
- values, 34 to 35

Problems, 49 to 54

R

R Audio In, 16

R jack, **18**

Range, 55

RCA, 15, 17

Recalling a setup, 40

Red, 36, 54

Red light, 50

Red plug, 16, 18

Remote control

- buttons, 24 to 25
- problems with, iii
- range, 55
- receiver, 21, 23
- using, x, 24 to 25

Resetting the lamp timer, 47

Resolution, ix, 34, 52 to 53, 55, 57

RGB, 58

Ring

- focus, 21, 22, 53
- zoom, **21, 22**

S

Safety instructions, iii, xiii to xiv

Screen image, 49

Screwdriver, 43, 45 to 46

Screws, 45 to 47

SECAM, 14

Service, 41, 51 to 52

Setting up, 1, 3

Settings, 31

SETTINGS screen, 34 to 35

Setup, recalling, 40

Setups, 26, 34 to 35, 38 to 40

Sharpness, 36 to 37

Shipping, 2

Signal, 53

Size, 55

Sleep mode, 5, 27
Sliders, 32
Smears, 42, 54
Softer images, 36 to 37
Software, 53
Sound system, 17
Source
 audio, 1, 16
 button, 24 to 26
 stereo, 1
 video, 1, 14
Speaker, 17
Specifications, 55 to 58
Status lights, 27, 51
Streaks, 26
Surface, 3, 53
S-Video, 3, 14 to 15
Sync, 38, 47, 53
Sync, comp, 34
Synchronize, 26
System Electronique pour Couleur Avec
 Memoire. see SECAM

T

Temp, 50 to 52
Temperature, 51, 56
Temperature light, 50 to 52
TFT, 55
Thin Film Transistor, see TFT

Timer, 47
Tint, 31, 38, 54
Tracking, 26, 34, 38, 47
Transport, 2
Troubleshooting, 49 to 54

U

Unpacking, 2

V

V position, 31, 38
Vacuum, 44
Ventilation, 41, 43, 51
Vertical lines, 26
VGA, 58
Video
 light, 27
 main menu, 31
 option menu, 37
 SETTINGS screen, 35
Video Graphics Array, see VGA
Video In, 15
Video-out, 15
Video source, connecting to, 14
Voltage
 input, 56
 warning, 42
Volume, 23 to 26, 34 to 35, 55

W

Warning lights, 49 to 50

Water, 42

Watts, 56

Weight, 56

White plug, 16, 18

Width, 56

Windows, 52

Wireless mouse, **1, 23**

Y

Yellow plug, 15

Z

Zoom, 55

Zoom ring, **21, 22**